

# *Water: Where and How*

Alternative sources  
of quality water in  
South-West part of  
Bangladesh

March 2021



WASH ALLIANCE  
International  
Accelerating WASH



Simavi  
Powerful women, healthy societies.



Uttaran

# *Water: Where and How*

Alternative sources  
of quality water in  
South-West part of  
Bangladesh

March 2021



WASH ALLIANCE  
Accelerating WASH

Simavi  
Powerful women, healthy societies.





## **Water: Where and How**

Alternative sources of quality water in South-West part of Bangladesh

### **Overall Supervision**

Shahidul Islam

### **Report preparation team**

Gouranga Nandy

Jahin Shams Sakkhar

Zahid Amin Shashoto

Hasina Parvin

Hedayet Ullah

Nazma Akter

Rushated Ullah

March 2021

### **Published by**



## **Uttaran**

House # 32 (1st Floor), Road # 10/A  
Dhanmondi R/A, Dhaka -1209, Bangladesh.

Tel: 88-02-91222, Cell: 88-01711828305

e-mai: [uttaran.dhaka@gmail.com](mailto:uttaran.dhaka@gmail.com)

web: [www.uttaran.net](http://www.uttaran.net)

### **Printed by :**

Digital Point, Ful Market More, Khulna.





# **T**able of **CONTENTS**

---

**F**orward

**A**bbreviations & Acronyms

**E**xecutive Summary

**1** Background

**2** Study Objectives

**3** Approach and Methodology

3.1 Document Review

3.2 Field Visit

3.3 Key Informant Interview

3.4 Focus Group Discussion

**4** Result and Analysis

4.1 Overview of the areas

4.2 Socio-Economic Condition

4.3 Sources of Water

4.3.1 Overall Scenario

4.3.2 Existing water option

**5. Major Challenges**

**6. Observations and Recommendations**

**R**EFERENCES

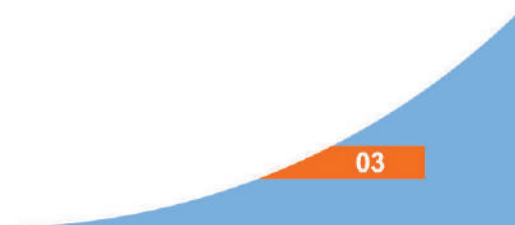



## Foreword



From over 35 years ago Uttaran has been struggling to ensure freshwater rights for the people of coastal areas of Bangladesh. Even though it has been one of the most talked about issues the community here is still deprived of fresh water. Now with climate change bringing new threats in all sectors, drinking water scarcity is reaching its peak due to salinity intrusion, sea level rise, frequent cyclones, and tidal surges. Nearly 4 million people from southwest Bangladesh suffer from drinking water crisis and the cost of a glass of fresh water is 3 times more than the cost in urban areas. The impact is felt the hardest by women, as 74% women in the area are responsible for fetching water for their families resulting in a crude cycle where 20% - 30% of women's life span is spent in searching and collecting fresh water.

Our close bond with the community and understanding about the local ecosystem has enabled us to understand the environmental and social challenges faced by the people to access drinking water and ways to adapt and overcome the crisis. Our right based approaches ensure people's right to access fresh water and simultaneously help develop various sustainable water options for the community. This has been one of most effective methods in helping communities to access fresh drinking water. Yet a lot more needs to be done.

The research critically evaluates the existing drinking water crisis in the south western coastal belt of Bangladesh and tries to explain evidence-based solutions to overcome the crisis. It also elaborates the social and economical aspects arising from the drinking water crisis and why we must urgently allocate our resources for its solutions.



My special thanks go to all the members who contributed to this study to explore the issues regarding drinking water scarcity and probable sources for the south-western coastal zone of Bangladesh. I express my heartfelt gratitude to the grass roots staff of Uttaran and members of Paani Committee, without whom gathering the required information would have been impossible. I am also grateful to the Department of Public Health, Khulna, NGO Forum For Public Health, and every other stakeholder who shared their valuable information with us. Special thanks should be given to the Government of Bangladesh, SIMAVI, UNDP Bangladesh, Care Bangladesh and BSRM for their generous support to Uttaran in the WASH sector over the year.

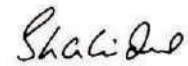

**Sahidul Islam**

Director

Uttaran

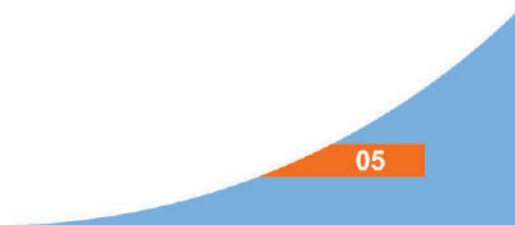



## Abbreviations & Acronyms

---

BBS	Bangladesh Bureau of Statistics
Beel	Low Land
BIWTA	Bangladesh Inland Water Transport Authority
BUET	Bangladesh University of Engineering and Technology
BWDB	Bangladesh Water Development Board
CEP	Coastal Embankment Project
DMB	Disaster Management Bureau
DPHE	Department of Public Health and Engineering
EC	Electric Conductivity
EP-WAPDA	East Pakistan Water and Power Development Board
FGD	Focus Group Discussion
FSM	Fecal Sludge Management
FY	Financial Year
Gher	Shrimp Farm
GIS	Geographical Information System
GoB	Government of Bangladesh
HHS	House Hold Survey
HYV	High Yield Varieties
JICA	Japan International Cooperation Agency
Kancha	The houses made with mud/soil
Khal	Smaller than rivers in size
km	Kilometer
Kobadak	The main river of the study area
LGED	Local Government Engineering Department
LGIs	Local Government Institution's
NGO	Non-Government Organization
O&M	Operation & Maintenance
Ppm	Parts per million
PSF	Pond Sand Filter
PSU	Policy Support Unit
PWD	Persons with Disability
RWH	Rain water Harvest
SPARRSO	Space Research and Remote Sensing Organization
SWM	Solid Waste Management
ToR	Terms of Reference
WASH	Water Sanitation and Hygiene
WATSAN	Water Supply and Sanitation
WHO	World Health Organization





## EXECUTIVE SUMMARY

This study incorporates a detail exploration of drinking water scarcity and probable sources in the south-western coastal area of Bangladesh. The objectives were to recognize and identify the sources of water and the constraints of potable water supply in the coastal area and to identify the water-scarce area of a coastal community of Bangladesh as well. Both primary and secondary data have been used to carry out the study. Extensively analysis has been done the published and unpublished paper in this regard.

Significant achievement has been achieved over most recent couple of decades in giving safe drinking water, but mostly withdrawing groundwater in Bangladesh. Yet in the recent years, groundwater based water supply in the coastal areas have been experiencing varioussignificant issues, principally arsenic sullyng, bringing down of the water table, salinity and unavailability of reasonable aquifers. The extent of utilizing and improved drinking water source was 97.9% in 2012-13, 98.5% in 2013 and 86.9% in 2015. Lack of safe drinking water has been identified as the number one issue in the daily life of the coastalpopulation.

Water conservation consists of actions that reduces the demand of water, improve efficiency in use and reduces losses and waste, and improves land management practices to conserve water. The natural subsystem of water resources system is: 1) the interlinked system of rivers, estuaries, canals, khals etc. 2) the floodplain 3) wetlands 4) haor, baor, beel (local names of different kinds of ponds filled with stagnant rain water), lakes etc. 5) ponds 6) tidal lands and water 7) groundwater aquifers. However, other than rivers, the natural reservoirs are scarce and thereby water conservation in rainy season for dry season use is limited. Water resources management is now a global concern, the main purpose of which is to provide adequate water for humans and the natural environment. The water management includes water utilization, water source conservation, monitoring and preservation of water quality.

In Bangladesh, the Ganga-Brahmaputra rivers contribute nearly 1000 million tons/yr. of sediment. The sediment contributed from these two rivers forms the Bengal Delta and Submarine fan, a vast structure that extends from Bangladesh to south of the Equator which is up to 16.5 km thick,





and contains at least 1130 trillion tones of sediment accumulating over the last 17 million years at an average rate of 665 million tons/yr. The Bay of Bengal used to be deeper than the Mariana Trench, the present deepest ocean point.

Natural hazards that come from increased rainfall, rising sea levels, and tropical cyclones are expected to increase as the climate changes, each seriously affecting agriculture, water and food security, human health, and shelter.

Water exists in solid, liquid and gaseous form. Oceans and seas are the main sources of water on earth, but this water is salty. The fresh liquid water sources on land surfaces and in the ground, constitute only 1% of the total water on earth. These fresh water sources have been formed by condensation of water evaporated mainly from the oceans and seas. The main sources of water in Bangladesh are surface waters in rivers, reservoirs, lakes, canals and ponds, and groundwater in shallow and deep aquifers. The rainwater is an alternative source of water. In Bangladesh, the sources of water are surface water and ground water. Both the sources may be fresh or saline.

Water is a sustainable asset and its accessibility relies upon the hydrological cycle. Secondly, scarcity of water is temporal and diurnal. Thirdly, there are distributional and social parts of water shortage. The fourth dimension is characterized as the anthropogenic (political, social and institutional) measurement that highlights the intervention and management practices.

The importance of institutional and political factors and conjointly emphasizing on the difference in availability and accessing water for explicit users clarify the context of freshwater deficiency in the coastal area and therefore the contestation of saline water and fresh water. The primary reasons for the expansions of salinity and freshwater shortage in the south-western coastal region are the withdrawal of water from major rivers in the upstream and siltation on the river bed, drainage congestion and water logging caused by the improper polder management.





Many causes have been identified to examine the difficulties of supplying fresh water i.e. saline water intrusion, reduction of upstream flow, sea level rise, disasters, polder, arsenic contamination, brackish shrimp cultivation, excessive use of underground water in an unplanned way, lack of appropriate aquifer etc.

This study found that the root causes i.e. saline water intrusion, reduction of upstream flow, sea level rise, disasters, polder, arsenic contamination, shrimp cultivation in brackish water, excessive use of underground water and lack of appropriate aquifer were highly influential for the disturbance of potable water supply in the coastal area. In addition, it has been showed that about two-third of the settlement areas as well as households fell into the water scarce zone.

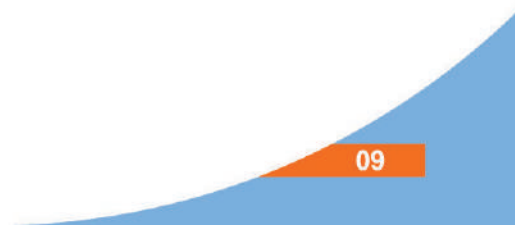

## Background

Life without water is not possible. All of we know that water is a fundamental resource for life and livelihood. The distribution, allocation, and management of water resource remain a significant concern. Especially, in many water-stressed regions of the world, it plays a vital role in social, financial and political strategies (Arseland Spoor, 2009). Access to safe drinking water is a basic well-being and financial advancement issue at national, regional and local levels (World Health Organization, 2011; Cvjetanovic, 1986).

The world's population is expected to reach eight billion by 2025, growing demands on drinking water supplies and water for food production are evident, and competing uses of limited resources are inevitable (UNDP, 2006).

Bangladesh is a small, lush country in South Asia; located on the Bay of Bengal. The country is divided between three regions. Most of the country is dominated by the fertile Ganges Delta, the largest river delta in the world. The northwest and central parts of the country are formed by the Madhupur and the Barind plateaus. The northeast and southeast are home to evergreen hill ranges.

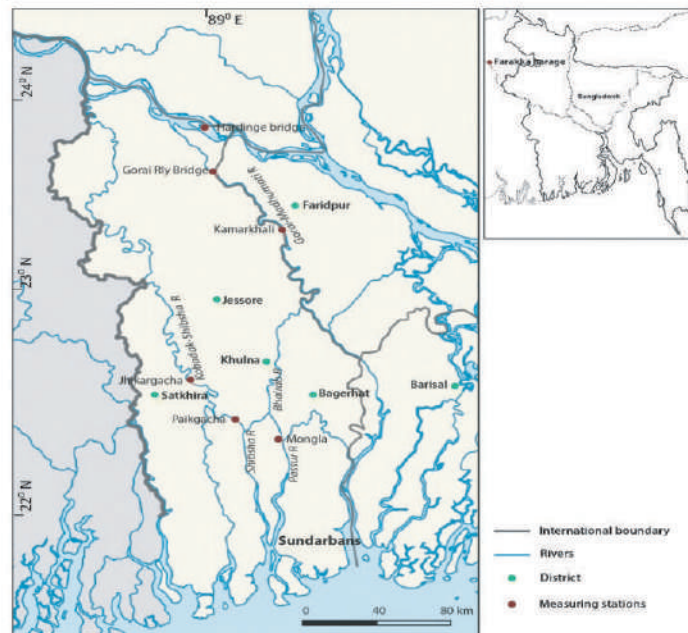





The Ganges delta is formed by the confluence of the Ganges (Padma), Brahmaputra (Jamuna, main channel of the Brahmaputra) and Meghna rivers and their respective tributaries. The Ganges unites with the Jamuna and later joins the Meghna, finally flowing into the Bay of Bengal. Bangladesh is called the Land of Rivers, as it is home to over 57 trans-boundary rivers. However, this, makes the resolution of water issues politically complicated, in most cases, as the country is a lower riparian state to India.

Bangladesh is predominantly rich fertile flat land. Most of it is less than 12 m (39 ft) above sea level, and it is estimated that about 10% of its land would be flooded if the sea level were to rise by 1 m (3.3 ft). 17% of the country is covered by forests and 12% is covered by hill systems. The country's shaor wetlands are of significance to global environmental science.



Bangladesh is home to much of the Sundarbans, the world's largest mangrove forest, covering an area of 6,000 square-km in the southwest region. The forest is a UNESCO World Heritage Site. All around one out of seven individuals has needed access to even least supplies of safe drinking water to fulfil their fundamental personal and residential needs. Several millions are left with no decision, however stroll for a considerable length of time to gather water from hazardous sources, for example unprotected well, streams or lakes utilized by animals (WASH United, Freshwater Action Network and Water Lex, 2012).

Significant achievement has been achieved over most recent couple of decades in giving safe drinking water, but mostly withdrawing groundwater in Bangladesh. Yet in the recent years, groundwater based water supply in the coastal areas have been experiencing various significant issues, principally arsenic sully, bringing down of the water table, salinity and unavailability of reasonable aquifers (PDO-ICZMP, 2004). The extent of utilizing and improved drinking water source was 97.9% in 2012-13, 98.5% in 2013 and 86.9% in 2015 (Bangladesh Bureau of Statistics, 2014; BBS, 2015; World Bank, 2016). Lack of safe drinking water has been identified as the number one issue in the daily life of the coastal population (Islam and Ahmad, 2004).

Arsenic and saline contamination make difficulties for supplying potable water to the underprivileged people of the country. The poor and destitute people cannot bear the cost of water technologies due to the financial crisis. Another measurement of hard to reach areas is the shortage of land for establishing the water technologies as they live on a small piece of land on street or embankment. In such cases, despite having the ability, individuals can't ensure safe water for themselves (NGO Forum for Public Health, 2012).

In the coastal areas of Bangladesh, the deficiency of drinking water is intense as the freshwater aquifers are not available at reasonable depths and the surface water is profoundly saline and turbid (Islam et al., 2014). Shrimp farming has been increased over the past two decades by essentially changing the local land use, and adversely influencing surface and groundwater resources (Datta et al., 2010).





WHO (2004) found that the groundwater is inadmissible for human consumption due to high salinity in the south-western region of the country (Khulna, Satkhira and Bagerhat district). Further, Ali (2006) reported that, saline water intrusion has caused issues in terms of severely declining the supply of potable water. Both surface and groundwater have been polluted by saline in this area. For this, rainwater is the most suitable for meeting drinking water needs. Islam (2015) also reported that rain water harvesting system (RWHS) is an important innovative livelihood option for safe drinking water in the exposed salinity-prone coastal area. The dwellers can collect water in monsoon and use for next five months in drought season only for drinking purpose.

Water conservation consists of actions that reduces the demand of water, improve efficiency in use and reduces losses and waste, and improves land management practices to conserve water. The natural subsystem of water resources system is: 1) the interlinked system of rivers, estuaries, canals, khals (smaller than rivers in size) etc. 2) the floodplain 3) wetlands 4) haor, baor, beel (local names of different kinds of ponds filled with stagnant rain water), lakes etc. 5) ponds 6) tidal lands and water 7) groundwater aquifers. However, other than rivers, the natural reservoirs are scarce and thereby water conservation in rainy season for dry season use is limited. Water resources management is now a global concern, the main purpose of which is to provide adequate water for humans and the natural environment. The water management includes water utilization, water source conservation, monitoring and preservation of water quality. In this paper the overall status of water resources of Bangladesh and its utilization in different areas with emphasis to conservation is described based on available information.

## **2. Study Objectives**

The objective of this study was to identify the existing alternative quality water sources in south-west part of Bangladesh.

### **Specific objectives of this study were:**

- a) To identify and establish evidence based strong rationale of existing water sources; and
- b) To influence relevant stakeholders including GoB line departments, donors, I/NGOs and raise public awareness on existing water sources.





### **3. Approach and Methodology**

Both primary and secondary data were generated in this study. Together qualitative and quantitative approaches were applied for data collection, analysis, and presentation. In this study, Satkhiraporashava was selected. The constraints of safe water supply have been identified by reviewing different published and unpublished documents. The approach and methodology followed and major specific activities carried out under the study are summarized below:

#### **3.1 Consultations And Field Visits**

The study team had many meetings with Uttaran officials. The meetings were very useful for better understanding of the assignment and getting a clear overview of the projects implemented by Uttaran. The study team finalized the modalities of work in consultation with Uttaran. Special emphasis was placed on the WASH facilities along with other important issues. The study team also visited the possible project locations to have an overview of the present situation in the field. Focus Group Discussions (FGDs) were finalized based on the findings of the field visits by the study team and discussions carried out with Uttaran officials.

#### **3.2 Document Review**

The study team collected, compiled and reviewed necessary relevant documents, particularly those on WASH situation in urban and national level surveys (PMID-WSUP, 2013; PSU-ICDDR'B-WaterAid, 2014; WHO-UNICEF, 2014).

#### **3.3 Focus Group Discussion**

A total of 4 Focus Group Discussions (FGDs) in the 4 selected areas were carried out in accordance with the ToR. The main purpose of the FGDs was to get views of the people of the Uttaran's working areas on different aspects of water sources, its uses and difficulties are usually facing people. Participation of different stakeholders including member of different professions, age groups, genders and social groups were ensured in the FGDs. FGDs being conducted at: (a) Two FGD's -one is women group and another is adolescent girl, at Rasulpur, Satkhira municipality; and (b) Two FGD's (male, female mix group) at Sultanpur 4 no councilor office, Satkhira municipality.

To understand the peoples' view and their understanding and observation about the Water sources and availability and water related problem fifteen key informant interview has also been taken.

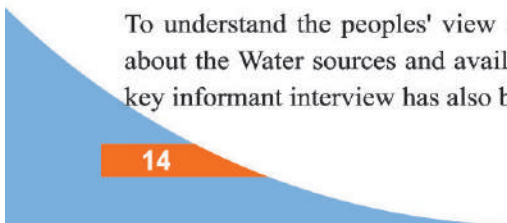

## 4. Result and Analysis

### 4.1 Overview of the areas

Satkhira is a district in southwestern Bangladesh and is part of Khulna Division. It lies along the border with West Bengal, India. It is on the bank of the Arpanagachhia River. The largest city and headquarter of this district is Satkhira.

The district consists of two municipalities, seven upazilas, 79 union parishads, 8 thana (police station) and 1436 villages. The upazilas are: Satkhira Sadar, Assasuni, Debhata, Tala, Kalaroa, Kaliganj and Shaymnagar Upazila. The two municipalities are Satkhira and Kalaroa.

Satkhira District has an area of about 3,817 square kilometers (1,474 sq. mi). It is bordered to the north by Jessore District, on the south by the Bay of Bengal, to the east by Khulna District, and to the west by 24 Pargana District of West Bengal, India.

The main rivers are the Kopotakho (Kobadak) river across Dorgapur union of Assasuni Upazila, Morichap River, Kholpetua River, Betna River, Raimangal, Hariabhanga, Ichamati, Betrabati and Kalindi-Jamuna River.

According to the 2011 Bangladesh census, Satkhira District had a population of 1,985,959. Males constituted 49.49% of the population and females 50.51%. Muslims formed 81.86% of the population, Hindus 17.70%, Christians 0.31% and others 0.12%. Satkhira District had a literacy rate of 52.07% for the population 7 years and above.

Most of the peoples of southern part of Satkhira depend on pisciculture, locally called gher. Main fruits are aam (mango), jaam (blackberry), kathal (Jackfruit), kola (banana), pepe (papaya), lichoo (litchi) etc. The main exports are shrimp. Contribute 18.5% of Bangladesh economy. Recently, the wide spread crab fattening is contributing heavily in Satkhira's economy. Sundarbans is the largest single block of tidal halophytic mangrove forest in the world, is a World Heritage Site and covers an area of 5,747 square kilometers (2,219 sq. mi).

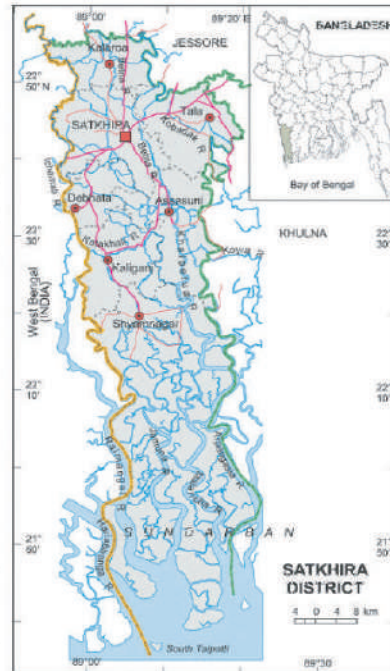





### **Coastal area**

Satkhira is one of the coastal district of Bangladesh where coastal areas are covering the south part of Bangladesh. The main rivers of Bangladesh derived from the Himalayas carry a high level of sediment and deposit it across the Bay of Bengal. This has led to major changes in the coastal region between 1989 and 2018. Over 30 years morphological changes many islands are losing land area. However, there has been an overall net gain in the land area due to the regular acceleration process in other parts of those islands. In the west, new islands were found, but no significant changes were observed. At the mouth of the Meghna estuary, noticeable variable changes have been observed with the formation of many new islands.



### **River system**

The rivers of Bangladesh mark both the physiography of the nation and the life of the people. About 700 in number, these rivers generally flow south. The larger rivers serve as the main source of water for cultivation and as the principal arteries of commercial transportation. Rivers also provide fish, an important source of protein. Flooding of the rivers during the monsoon season causes enormous hardship and hinders development, but fresh deposits of rich silt replenish the fertile but overworked soil. The rivers also drain excess monsoon rainfall into the Bay of Bengal. Thus, the great river system is at the same time the country's principal resource and its greatest hazard.

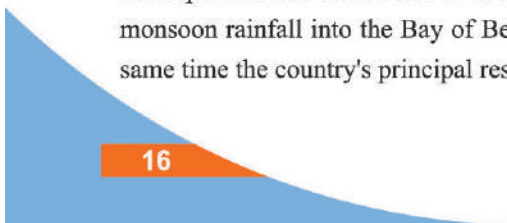





The second system is the Padma-Ganges, which is divided into two sections: 258 kilometers (160 mi) segment, the Ganges, which extends from the western border with India to its confluence with the Jamuna some 72 kilometers (45 mi) west of Dhaka, and 126 kilometers (78 mi) segment, the Padma, which runs from the Ganges-Jamuna confluence to where it joins the Meghna River at Chandpur. The Padma-Ganges is the central part of a deltaic river system with hundreds of rivers and streams-some 2,100 kilometers (1,300 mi) in length-flowing generally east or west into the Padma.

The Ganga-Brahmaputra rivers contribute nearly 1000 million tons/yr. of sediment. The sediment contributed from these two rivers forms the Bengal Delta and Submarine fan, a vast structure that extends from Bangladesh to south of the Equator which is up to 16.5 km thick, and contains at least 1130 trillion tones of sediment accumulating over the last 17 million years at an average rate of 665 million tons/yr. The Bay of Bengal used to be deeper than the Mariana Trench, the present deepest ocean point.

During the annual monsoon period, the rivers of Bangladesh flow at about 140,000 cubic meters per second (4,900,000 cu ft./s), but during the dry period they diminish to 7,000 cubic meters per second (250,000 cu ft./s). Because water is so vital to agriculture, more than 60% of the net arable land, some 91,000 square kilometers (35,000 sq. mi), is cultivated in the rainy season despite the possibility of severe flooding, and nearly 40% of the land is cultivated during the dry winter months. Water resources development has responded to this "dual water regime" by providing flood protection, drainage to prevent over flooding and water logging, and irrigation facilities for the expansion of winter cultivation.

Major water control projects have been developed by the national government to provide irrigation, flood control, drainage facilities, aids to river navigation and road construction, and hydroelectric power. In addition, thousands of tube wells and electric pumps are used for local irrigation. Despite severe resource constraints, the government of Bangladesh has made it a policy to try to bring additional areas under irrigation without salinity intrusion.

Water resources management, including gravity flow irrigation, flood control, and drainage, were largely the responsibility of the Bangladesh Water Development Board.



Other public-sector institutions, such as the Bangladesh Krishi Bank, the Bangladesh Rural Development Board, the Bangladesh Bank, and the Bangladesh Agricultural Development Corporation were also responsible for promotion and development of minor irrigation works in the private sector through government credit mechanisms.

### **Flood**

About 80% of Bangladesh's rain falls during the monsoon season. The monsoons result from the contrasts between low and high air pressure areas that result from differential heating of land and water. During the hot months of April and May hot air rises over the Indian subcontinent, creating low-pressure areas into which rush cooler, moisture-bearing winds from the Indian Ocean. This is the southwest monsoon, commencing in June and usually lasting through September. Dividing against the Indian landmass, the monsoon flows in two branches, one of which strikes western India. The other travels up the Bay of Bengal and over eastern India and Bangladesh, crossing the plain to the north and northeast before being turned to the west and northwest by the foothills of the Himalayas.





There are no precautions against cyclones and tidal bores except giving advance warning and providing safe public buildings where people may take shelter. Adequate infrastructure and air transport facilities that would ease the sufferings of the affected people had not been established by the late 1980s.

Efforts by the government under the Third Five-Year Plan (1985-90) were directed toward accurate and timely forecast capability through agrometeorology, marine meteorology, oceanography, hydrometeorology, and seismology. Necessary expert services, equipment, and training facilities were expected to be developed under the United Nations Development Programme.

Natural hazards that come from increased rainfall, rising sea levels, and tropical cyclones are expected to increase as the climate changes, each seriously affecting agriculture, water and food security, human health, and shelter.





Sea levels in Bangladesh are predicted to rise by up to 0.30 meters by 2050, resulting in the displacement of 0.9 million people, and by up to 0.74 meters by 2100, resulting in the displacement of 2.1 million people.

#### **4.2 Sources of Water**

Water exists in solid, liquid and gaseous form. Oceans and seas are the main sources of water on earth, but this water is salty. The fresh liquid water sources on land surfaces and in the ground, constitute only 1% of the total water on earth. These fresh water sources have been formed by condensation of water evaporated mainly from the oceans and seas

(Ahmed and Rahman 2000).The main sources of water in Bangladesh are surface waters in rivers, reservoirs, lakes, canals and ponds, and groundwater in shallow and deep aquifers. The rainwater is an alternative source of water.

In Bangladesh, the sources of water are surface water and ground water. Both the sources may be fresh or saline.

##### **4.2.1 Surface water**

Surface water sources are categorized as rainfall, transboundary flow, water on standing water bodies (water storage in reservoir, water bodies such as river, lake and pond), water on seasonal wetlands, and in-stream storage. These are describing below:

- i) **Rainfall** Average annual rainfall of the country is about 2360 mm (1960-1997). In recent years northwest and southwest region of the country receives less rainfall compared to other parts. About 20% of the average annual rainfall occurs in dry season (November-May) in northwest region but the monthly distribution of this amount is highly uneven.
- ii) **Transboundary flow** Bangladesh shares 57 transboundary rivers, 54 incomings from India, 3 from Myanmar. Among the rivers, the Ganges, the Brahmaputra and the Meghna drain about 1.08 million sq.km., 0.58 million sq.km. and 0.09 million sq.km. respectively. Total annual volume of water that enters the country from the transboundary rivers is about 1000 billion cubic meters.





Crucial issue of the transboundary flow is the diminishing values of the lean season inflow to Bangladesh. Due to indiscriminate and unilateral upstream withdrawal of water of common rivers during lean period when the country needs it (in absence of any rainfall), a water crisis is prevailing in Bangladesh. The southwest part (Ganges Dependent Area) of the country is the most affected region due to upstream withdrawal of the Ganges at Farakka where irreversible environmental degradation is happening. Peak monsoon flow is often causing flood in Bangladesh. In normal year, about 20% of the country is inundated which in extreme cases may rise to 60% like 1987, 1988, 1998 flood.

- iii) Water on standing water bodies in addition to natural rivers, water is retained in localized low pockets (beels/baors) and ponds in dry season. Kapatai lake is the lonely reservoir in the country that has storage capacity. Total volume of such standing water bodies is about 0.61 billion cubic meters.
- iv) Water on seasonal wetlands Floodplains (about 80% of the total area of the country) become seasonal wetlands during monsoon (July-October) because of slow drainage of huge transboundary flow and local rainfall excess. The seasonal wetlands remain inundated from a few days to several months (May-November). Estimated volume of water stored in these seasonal wetlands/floodplains is about 2.69 billion cubic meters. This seasonal storage has virtually no contribution during dry season.
- v) The numerous channels crisscrossing the entire country, in flowing stage, store water till these are completely dries. Estimated volume of channel storage is of the order of 0.5 billion cubic meters.

It can be mentioned that, traditionally, before and during the early stages of tube wells installation, rural water supply was largely based on protected ponds. There are about 1,288, 222 ponds in Bangladesh (BBS, 1997) having an area of 0.114 ha per pond and 21.5 per mouza. About 17% of these ponds are derelict and probably dry up in dry season. The pond was the basic water sources both drinking and other uses in the south-west coastal region of Bangladesh. Not only this, here is a traditional practice of rain water harvesting system. People usually collected rainwater through roof of houses and preserve it mud-made container.

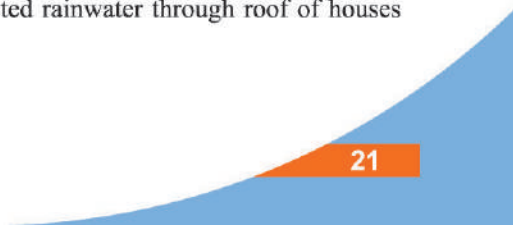





#### 4.2.2 Groundwater

The main source of ground water is the recharge from surface water. Most of the areas of Bangladesh have been formed from the sedimentary alluvial and deltaic deposits of three major rivers. These alluvial deposits have formed mainly an unconfined aquifer for most of the area of the country. Groundwater was supposed to be one of the major natural resources of the country except the safe drinking water supplies. But the presence of Arsenic in shallow aquifer has completely changed the situation. It is estimated that about 16% of present population of 123.15 million is exposed to arsenic contamination exceeding Bangladesh standard (0.05 mg/l). About 74452 sq.km. of groundwater use area (about 50% of the country) is unsuitable for use by hand tubewells (as a source of drinking water according to WHO standard) due to arsenic.







The amount of ground water which can be obtained from an area depends on characteristics of the underlying aquifer and the extent and frequency of recharge. An aquifer has interconnected pores filled with water which may be considered as a network of interconnected pipes through which water flows at a very slow rate. These interconnected pores provide both storage and flow, or conduit functions in an aquifer (Ahmed and Rahman 2000).

Groundwater is the main source of water supply in urban and rural areas of Bangladesh. Groundwater in Bangladesh is available abundantly, but the availability of groundwater for drinking purposes has become a problem for the following reasons:

- \* Arsenic in groundwater;
- \* Excessive of dissolved iron;
- \* Salinity in the coastal areas;
- \* Lowering of groundwater level;
- \* Rock/stony layers in the hilly areas.

**Arsenic in groundwater:** The concentration of arsenic more than permissible limit is toxic to human body. According to the WHO guideline value the desirable maximum acceptable concentration of arsenic in drinking water should be 0.01 mg/l. In Bangladesh, the maximum acceptable concentration in drinking water is 0.05 mg/l. Symptoms of arsenic toxicity leading to cancer may occur due to excessive intake of arsenic in the human body over a longer period.

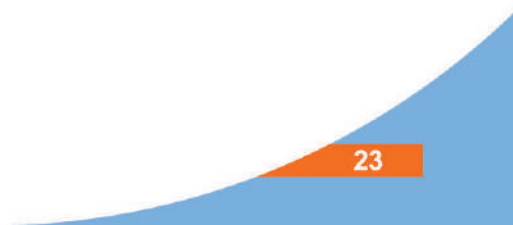

Excessive dissolved iron: In Bangladesh, the permissible limit of iron in groundwater is 1 mg/l but iron content up to 5 mg/l is acceptable for rural water supply. It has been observed that iron content exceeds this limit in many handpump tubewells. People are reluctant to drink this water mainly due to its bad taste. Water with high iron content is not used for cooking, washing and other domestic purposes.

Salinity in coastal areas: The concentration of dissolved minerals in groundwater is higher than that in surface water. The coastal belt of Bangladesh, extended over 86 upazilas, is identified as a problem area where complex hydrogeological conditions and adverse water quality make water supply difficult as compared to other parts of the country. Unlike other areas of Bangladesh, groundwater of acceptable quality at relatively shallow depths, which can be easily withdrawn by conventional handpump tubewells is not available in most parts of the coastal area. In some places, low salinity water has been found in deep aquifers. Based on the availability of fresh groundwater, the DPHE has divided the coastal regions into three types of areas. There are still many areas in coastal belts where low salinity groundwater is not available within a depth of 1,100 ft. In rural water supply chloride content, up to 1,000 ppm is acceptable for coastal belts where the normal acceptable limit is 250 ppm (Ahmed and Rahman 2000).

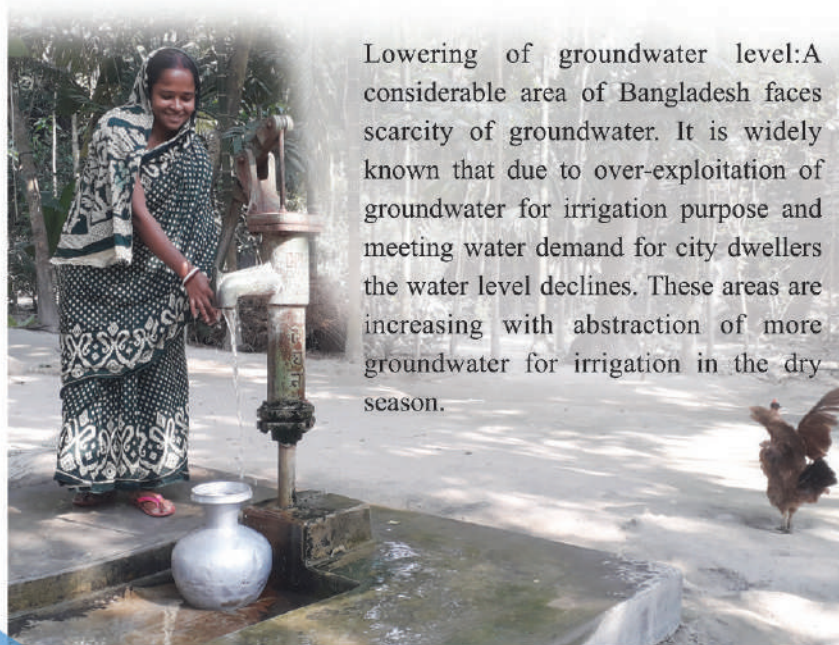

Lowering of groundwater level: A considerable area of Bangladesh faces scarcity of groundwater. It is widely known that due to over-exploitation of groundwater for irrigation purpose and meeting water demand for city dwellers the water level declines. These areas are increasing with abstraction of more groundwater for irrigation in the dry season.



Rock/Stony layers in hilly areas:Drilling of tube wells for rural water supply in Chittagong Hill Tracts districts of Bangladesh is difficult due to the presence of hard formations in the subsurface. In most cases conventional drilling methods for the installation of handpumps cannot penetrate these hard rock formations.

#### **4.2.3 Rainwater**

Bangladesh is a tropical country and receives heavy rainfall due to north-easterly winds during rainy season. Rain water is a potential source of Bangladesh. In the coastal districts, particularly in the offshore islands of Bangladesh, rainwater has been used for drinking purposes since time immemorial. The protected ponds annually replenished by rainwater are a main source of water supply in the coastal area. On the other hand, rainwater harvesting is one of the traditional system of coastal districts like Satkhira, Khulna and Bagerhat. But the existing collection, storage and use of rainwater system are not scientific so need to proper attention to developing the system. Rainfall in our country is not equally distributed in every month or every area of the country. So, a water supply system completely based on rainwater requires large rainwater storage reservoirs.

#### **4.3.1 Overall Scenario**

The natural surface water resources in Bangladesh are mainly derived through the major river systems and their tributaries. The flow distribution characteristic in the river system is a combination of upstream inflows and run-off generated from rainfall within Bangladesh. In the southern regions, the distribution is also affected by tidal conditions. Surface water is abundant in the wet season in Bangladesh. An estimated 795,000 million cubic meter (Mm<sup>3</sup>) of surface water is discharged per year through the Ganges-Brahmaputra system, in the downstream of the confluence of the Ganges and the Brahmaputra. This is equivalent to 5.52m deep water over a land area of 144,000 square km. There are other rivers discharging surface water into the Bay of Bengal. In dry season country suffers from acute shortage of both surface and groundwater (BUET, 2004).

Bangladesh experiences four main types of floods: monsoon floods from the major rivers; local flooding due to drainage congestion, flash floods in the eastern and northern rivers; floods caused by high tides and storm surges in the coastal areas. During the June-September monsoon,

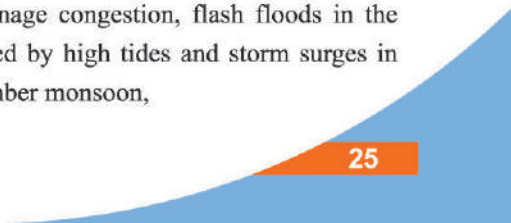





Bangladesh receives about 80% of annual precipitation, averaging 2300mm, but varying from as little as 1200mm in the west to over 5000mm in the east. Runoff from adjacent riparian is generated by rainfall which averages 5000mm over the Himalayas, and exceeds 10,000mm over the Meghalaya plateau north to Sylhet. Together inflows and rainfall causes peak floods in the Ganges, Brahmaputra and Meghna rivers in the period July-August, and on average 22% of the country is flooded annually. Drought is also a problem in Bangladesh, particularly in the North-West regions during the spring where there are few surface water resources, and agricultural production is heavily reliant on groundwater resources.

Groundwater is the main source of water supply in urban and rural areas of Bangladesh. Except for few hilly regions Bangladesh is entirely underlain by water bearing aquifers at depths varying from zero to 20m below ground surface. Groundwater in Bangladesh is available in adequate quantity, but the availability of groundwater for drinking purposes has become a problem some specific reasons which are describe earlier. So, it may be said that in spite of heavy rainfall, readily accessible groundwater and large river systems in this country, at present water scarcity for drinking purpose is the major problem in Bangladesh due to arsenic contamination in groundwater and surface water pollution by point sources and non-point sources.

#### **4.3.2 Existing Water Option (Uttaran- Finding Freshwater in a Changing Climate)**

##### **Raised Deep Hand Tubewell**

Because of the geographical settings and unique climatic conditions of southwest coastal region in Bangladesh, safe drinking water is scarce in this particular region. Under these conditions the saturation zones, the underground sources of water, offers some fresh, safe and drinkable water. But the major hurdle in accessing water from this sources are that the aquifers in this region are very deep down the surface. One of the most convenient processes of extracting this fresh water is by installing a deep hand tube well. In the southwest region, the tube wells need to reach almost around 700 feet to 1200 feet under the surface to get access to the fresh water source.



The concerned regions are prone to natural disasters like floods and cyclones. Cyclones in these regions are accompanied with tidal surges. Thus these regions become prone to water logging and it remains water logged for almost 6 to 8 months every year. While installing the tube

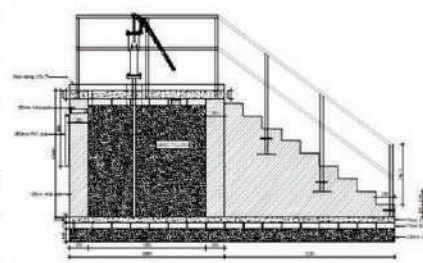

Figure: Plan and section of Raised Platform

wells we need to take into account the issues. To combat these challenges the hand tube well platform is raised above tidal surge or flood level. After setting up the tube well with this precaution, we name this water option as the raised deep hand tube well.

### Rain Water harvesting system

Rainwater is one of the alternative sources of safe drinking water and is particularly important for the southwest coastal region of Bangladesh. Both ground and surface water in some areas of southwest districts, particularly lower parts of Khulna and Satkhira district are saline, thus making it unusable. The system is particularly designed for those areas where there is scarcity of fresh water. The monsoon season of Bangladesh provide plenty of rainfall

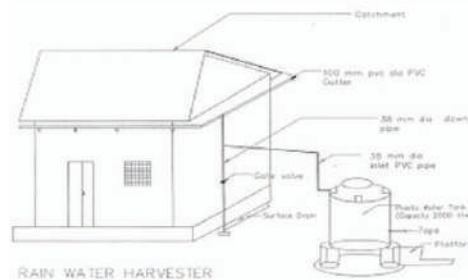
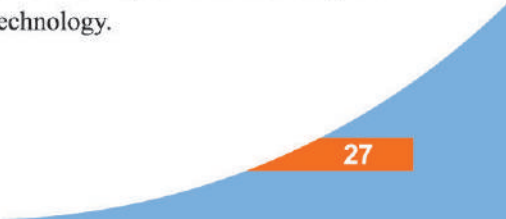

Figure 2 Rain Water Harvesting System: Source: DPHE

which can be collected at individual household levels and stored throughout the year for drinking purpose mainly. Rain water has been identified as a safe source of drinking water. Rain water harvesting is basically the accumulation and deposition of rainwater for reuse on-site, rather than allowing it to run off.

### Design

Rainwater can be collected from rivers or roofs, and in many places the water collected is redirected to a deep pit or reservoir with percolation. The system requires a very simple and cost effective technology.





For individual household, rainwater harvesting system is found to be sustainable. Generally, a 100 mm diameter outlet is set around edge of the roof of the house and is used a catchment for the rainwater. The outlet is directed to a 38 mm diameter down pipe that channel the water through an inlet pipe of 36 mm diameter into a plastic water tank placed on a platform for storing. The capacity of the tank may vary. The down pipe contains a valve to regulate the surface catch. The setup cost is around BDT 18000-20000 based on the size of the water tank. Within this cost the water tank can store up to 2800-3200 L of water. This system needs to be cleaned once a year and the maintenance cost is BDT 200 per year. In the recent years, rain water harvesting is being promoted in the community level as well, particularly in schools. Big water tanks are installed where at time 20000L-25000L of water can be stored so that it can serve a bigger community

The rain water harvesting system is important for the dry season. Normally, November to April is the dry season in Bangladesh when water becomes scarce and water salinity increases.

The RWHS is supposed to supply drinking water need for a family during this period. With 2800 L of water a family of 5 members can get water 3.1 L per day for the six months of dry season.

### **Shallow Shrouded Tube Well (SST)/ Very Shallow Shrouded Tube Well (VSST)**

In the high salinity coastal areas it has been found that fresh water is available in small pockets of shallow aquifers composed of fine sand at 15 to 20 m depth. This may be due to accumulation of rainwater in the topmost aquifer or dilution of arsenic contaminated groundwater by fresh water recharging each year by surface and rain waters. However, the particle size of soil and the depth of the aquifer are not suitable for installing a normal tubewell. To get water through these very fine-grained aquifers, an artificial sand packing is required around the screen of the tubewell. This artificial sand packing, called shrouding, increases the yield of the tubewell and prevents entry of fine sand into the screen.

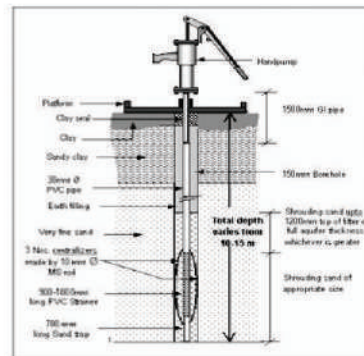
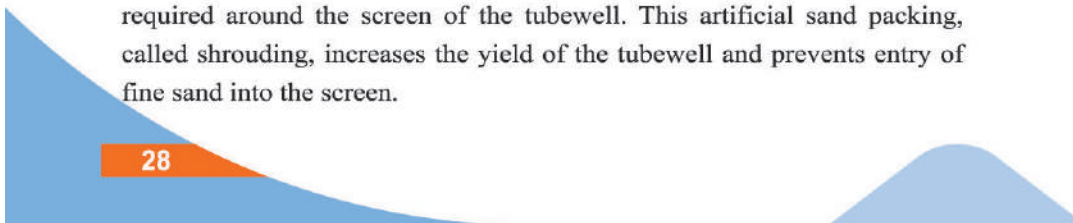

Figure: Shallow Shrouded Tubewell





These low-cost hand pump tubewell technologies have been designed and installed in the coastal areas to collect water from very shallow aquifers formed by displacement of saline water by fresh water. The SST/VSSSTs can be convenient methods for withdrawal of fresh water in limited quantities. Over-pumping may yield contaminated water. Installation of low capacity pumps may prevent over exploitation of shallow aquifers. The systems may be considered suitable for drinking water supply for small settlements where water demand is low. A shallow/very shallow tube well is shown in Figure.

### **Pond Sand Filter**

PSF is a simple, low-cost technology with very high efficiency in turbidity and bacterial removal, constructed with locally available materials and trained masons. Its operation and maintenance is also simple and cheap. This is a surface water treatment plant where source of water is pond water. Generally a reserved pond with enough space on the bank is needed to install PSF. Generally a medium sized PSF can support 150-250 households and takes near about 1, 50,000 -170,000 Tk. for installation.

PSF uses a tank with 5-6 chambers or layers. Each chamber is filled with gravels of different sizes to filter both coarse and fine sands and other materials such as bacteria from water. The pond water is channeled through a tube well to the tank. After passing through different filtering chambers the purified water settles at the last chamber which is then collected through a pipe or multiple pipes usually known as tap.



Conventionally, pond water is pumped through hand tube well. But it can also be pumped through a solar pump or a fuel run motor. It has been found that hand tube well system is most cost effective but time consuming while the fuel run motor is more efficient but expensive to run. The solar motor is cost effective, takes less time than tube well to pump water, and most importantly is able to serve 24 hours a day.



Therefore, it is found to be the most suitable option of PSF under the economic and climatic context of Southwest region. In addition, if a large enough tank can be installed, the purified water can be distributed through multiple mini pipe system which will reduce the hurdle of the households to fetch water from the tank especially for those who live relatively far from the pond.

The committee involvement in operation and maintenance is absolutely essential to keep the system operational. It has been found from the field that due to lack of cooperation and planning community people are less willing to bear the cost of maintenance of PSF. A proper planning and local government cooperation is essential for community maintenance of PSF. In addition, it should be kept in mind that the pond is not connected with any other drainage system which may contaminate it and spread water borne diseases as locals complain about the quality of water. They mostly use it for cleaning and shower purpose.

#### **Arsenic and Iron Removal Plant (AIRP)**

Apart from salinity intrusion, underground aquifers in the southwest coastal region of Bangladesh are also highly affected with arsenic and iron. To overcome this threat arsenic iron removal plant (AIRP) is found to be a good alternative technology to ensure arsenic and iron free water. AIRP is capable of removing 90-98 % iron and 70-75% arsenic from water. Similar to PSF, this plant also requires tube well to pump the water inside the tank after which purified water can be collected through a tap. This technology is sustainable for a small community as one AIRP can support around 10 families. Its maintenance and installation cost is affordable.

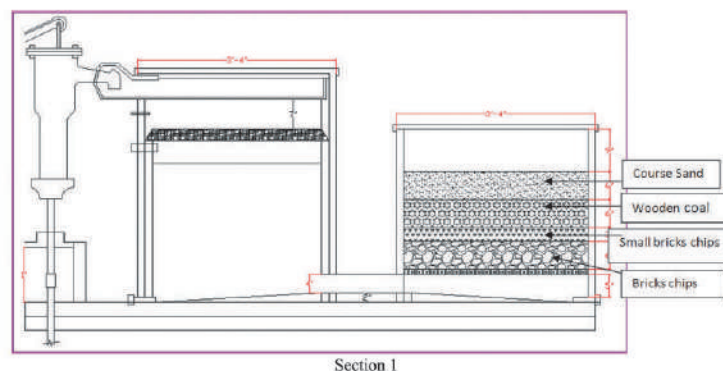

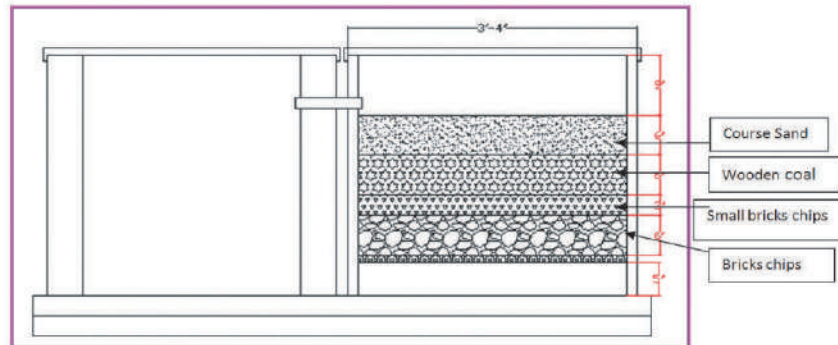

Section 2

AIRP uses similar technological principle as PSF. Water is pumped inside and passed through several layers of sand, coal and brick chips and the purified water is collected through pipe or tap. Pipe line can be added with the outlet tank so that water can be distributed to households through pipes. The total plant except the tube well will cost BDT 22000 - 25000 to install. Like PSF, AIRP needs deep community involvement and association from local Govt. for sustainable maintenance and functioning.

### Reverse Osmosis (RO)

Reverse osmosis is a water purification technology which is used to remove dissolved solids and larger particles from drinking water. The technique uses a semipermeable membrane through which a solution is passed by applying high pressure. After applying the pressure, the solute (salt) is retained on the pressurized side of the membrane and the solvent (water) is allowed to pass through to the other side for collection as fresh water. To be selective the membrane is set to not allow large molecules and ions to pass through the pores but it should allow smaller component of solutions (such as the water) to pass through. Underground saline water as the source is recommended to ensure less turbidity and lasting of the membrane but saline surface water can also be used due to easy availability.

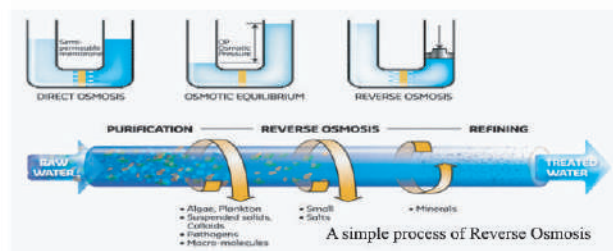



In coastal Bangladesh, this process can be very effective considering that most of the areas are saline. The setup cost of this process can be quite expensive considering modern technologies are being used. The maintenance cost is also quite expensive as well as it requires electricity. Solar energy can be used as an alternative source of electricity and thus will help to reduce the running cost. The water produced from this plant can also be piped through a mini piped water supply system to meet the demand of the community.

This system has now also become a strong SME. Many people in the coastal areas have established small scale RO plant from where they are able to supply fresh water for 200-600 families depending on the size. The setup cost for such RO plant is around BDT 400,000-500,000.

#### **Mini Piped Line:**

In some hard to reach areas of southwest coastal Bangladesh, mini piped line system is the best option to provide fresh water supply for the locals. In areas where there is no fresh water supply, water from other nearby areas can be supplied using this system. Mini piped line can be connected to a lot of different water options. For example, In Koyra and Asasuniupazila of Satkhira district ground water is supplied to the people through mini piped lines, where as in MonglaUpazila surface water is treated and then supplied. Pipe lines are connected to the water supply and then several connection points are installed in some community places for the people to collect water. The system has electricity/solar run water pump, an overhead tank, long pipelines to cover large area and collection points.





### Household Filters

Surface water containing impurities can be clarified by a pitcher filter unit or a small sand filter at the household level. In the next few lines we are highlighting the two most effective household filters.

#### Jar Filter/Kalshi Filter

There was extensive use of jar filter system for purification of water in rural area of Bangladesh. In some areas it is still used. This system is more effective especially for clearing dirt and filth from water. It is an old method of water purification. Jar filters are constructed by stacking a number of jars (Kalshis), one above the other, containing different filter media. Raw water is poured in the top Kalshi and filtered water is collected from the bottom one. In this process, water is mainly purified by the

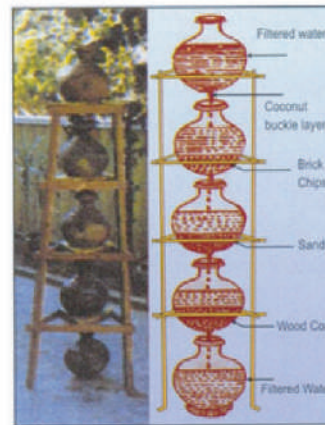

Figure: JAR/KALSHI Filter

mechanical straining and adsorption depending of the type of filter media used. This process is very cost efficient since it requires only Tk. 500-700/- for the complete process and also the maintenance cost involved is also minimal.

#### Small Household Filter

Small household filters can be constructed by stacking about 300-450 mm thick well graded sand on a 150-225 mm thick coarse aggregate in a cylindrical. The container is filled with water and the filtered water is collected from the bottom. It is essential to avoid drying up of the filter bed. Full effectiveness of the filtration process is obtained if the media remain in water all the time. The small household filter has been able to offer much purified water. But being a household filter, the quality of water it offers is exemplary.

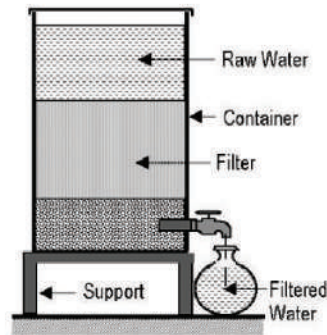
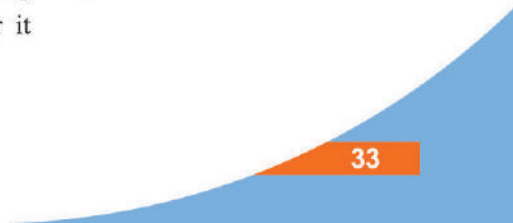

Figure – Small household filter







## 5. Major Challenges

Water plays a crucial role for improving human well-being (Crow and Sultana, 2002). It is considered 'safe' when it's free from pathogenic agents, and harmful chemical substance, and satisfying to taste i.e. ideally free from colour and odour, and usable for domestic purposes (Park, 2015). Scarcity of water must be comprehended by considering the whole measurement.

Firstly, water is a sustainable asset and its accessibility relies upon the hydrological cycle. Secondly, scarcity of water is temporal and diurnal. Thirdly, there are distributional and social parts of water shortage. The fourth dimension is characterized as the anthropogenic (political, social and institutional) measurement that highlights the intervention and management practices (Mehta, 2003). The importance of institutional and political factors and conjointly emphasizing on the difference in availability and accessing water for explicit users clarify the context of freshwater deficiency in the coastal area and therefore the contestation of saline water and fresh water (Alamgir, 2010). The primary reasons for the expansions of salinity and freshwater shortage in the south-western coastal region are the withdrawal of water from major rivers in the upstream and siltation on the river bed, drainage congestion and water logging caused by the improper polder management (Islam and Kibria, 2006). Many causes have been identified to examine the difficulties of supplying fresh water i.e. saline water intrusion, reduction of upstream flow, sea level rise, disasters, polder, arsenic contamination, brackish shrimp cultivation, excessive use of underground water in an unplanned way, lack of appropriate aquifer etc.

### Saline water intrusion

Potable water is most likely going to become a serious issue especially in the coastal area due to saline water intrusion (NGO Forum for Public Health, 2012). A natural appalling situation caused by saline water intrusion is a noteworthy issue and that renders the groundwater unfit for consumption in the south-western coastal region of Bangladesh (Ahmed, 2006; NWPo, 1999). It is owing to decrease of freshwater spillout of upstream (mostly inferable from the establishment of the Farakka Barrage on the Ganges River, near the border of Bangladesh) is required to be irritated by climate change and sea level rises, that has brought about the saline water intrusion being pushed further toward the north (Nicholls et al., 2007).

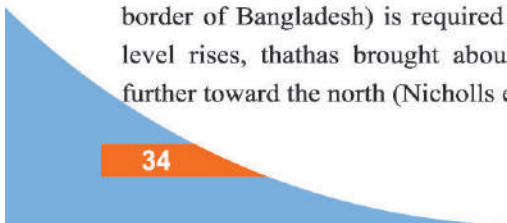





The effect of saline water intrusion is highly seasonal while minimum during the monsoon when the GBM (the Ganges, Brahmaputra and Meghna) Rivers release around 80% of the annual freshwater flow. In the winter months, the saline water starts to penetrate inland and the influenced regions rise forcefully from 10% in the monsoon to more than 40% in the dry season (DMB, 2000).

#### **Reduction of upstream flow**

Reduction of the stream flow of the River Ganges happens (the Ganges along with the Padma is the largest river system that flows over Bangladesh) in dry season due to over withdrawal of water in the upstream. India diverts at least 40,000 cusecs water through a feeder canal from the Farakka Barrage to the River Hugli to ensure proper navigation at Kolkata port. The flow through the River Gorai, the perpetual distributaries of the River Ganges has been declining since the mid-1970s and the dry season flow has quit from the end of 1980s.

This has already risen up the salinity level of the water in Khulna and the Sundarbans (the largest mangrove forest in the world). It has additionally increased salinity in the River Balashar and associated rivers and canals of the country (CEGIS, 2003; Tran and Shaw, 2012). During dry season, a mix of extremely low flow and increased salinity quickened the procedure of sedimentation in the river bed, which eventually stifled the river and radically lessened its drainage capacity. This is the manner by which drainage congestion turned into a usual nature of that river, consequently in the overbank spillage during each peak season. Thus, the area becomes waterlogged for a certain period of the year (Ahmed, 2008).

#### **Sea level rise**

Sea level rise due to global warming continued sedimentation of the rivers and floodplains and subsidence of the Ganges basin are all factors that might result to raise the sea level with respect to land. It has been estimated that the increase of mean sea level from 4.5 to 23.0 cm by 2025 and from 6.5 to 44.0 cm by 2050 (NWMP, 2001). The rising sea level will create new salinity affected areas, which might generate further scarcity of potable water.

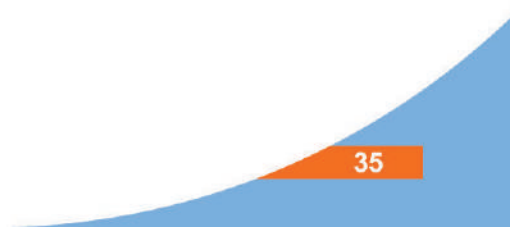



### **Disasters**

The south-western region of Bangladesh often experiences natural disasters (e.g. water logging, cyclones, tidal surges, floods, river erosion etc.) which are responsible for the decimation of drinking water sources. The annual recurrence of disasters is 6.11, making Bangladesh the prominent disaster-prone countries of the world. The country receives the end of about two-fifths of the world's total impact from storm surges (Murty and El-Sabh, 1992; World Bank, 2005). During and immediately after cyclone AILA (hit on 25 May, 2009), all freshwater sources were contaminated with dirty saline water. Supply of drinking water became the most striking challenge and people were forced to drink that unsafe water in the affected area (Kumar et al., 2010; Haque et al., 2010; Halder and Zaman, 2010).

### **Polder**

Bangladesh is shaped by the deltaic processes and the formation of its significant south-western coastal part is yet active (Agarwal et al., 2003). A total of 123 flood control polders including 5,107 km of embankment have been constructed covering approximating 1.5 million ha of the coastal area under the Coastal Embankment Project (CEP) to prevent tidal flooding. Among them, about one million ha lies in the south-western part (Islam et al., 2006; Guimaraes, 2002; Chowhury and Rasul, 2011). The polder/enclosure systems disconnected the lowlands from the rivers (Haq, 2000). Because of the construction of the polders on both sides of the rivers, the natural process of tidal inundation was stopped and resulting into water logging as well as drainage problem caused by the rising of channel bed due to siltation. During the dry season, accumulation of salt in the topsoil through capillary action is gradually increasing the salinity in the areas which were formerly wetlands (Islam and Kibria, 2006; Haq, 2000).

### **Arsenic contamination**

Severe arsenic tainting of groundwater has disrupted the idea of using shallow tube-wells for safe drinking water throughout the country (Safiuddin and Karim, 2003). The southwest coastal region has been facing for the crisis of pure drinking water due to arsenic contamination in groundwater. However, the number of arsenic affected rural villages is lower than the saline affected villages in the coastal area. (Harun and Kabir, 2013; Rahman et al., 1997; Uttaran, 2003; WHO, 2004).

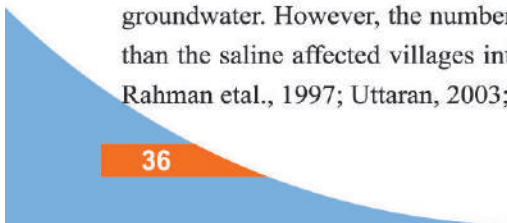





### **Cultivation of brackish water shrimp**

Shrimp cultivation in brackish water is a serious concern which allowing saline water intrusion into the adjacent agricultural land, groundwater acquirer and waterways in the coastal area of the country (Flaherty et al. 2000). This salinization process reduces fresh water supplies not only for agriculture but also for drinking and domestic needs (Deb, 1998; Patil and Krishnan, 1998).

### **Excessive use of underground water in an unplanned way**

The absence of surface water for irrigation during dry season has constraints to the agriculturists to exploit underground water extensively leading to a lowering water table beyond the suction limits of shallow tube-well, making millions of shallow tube-wells dysfunctional. This over-extraction of groundwater is one of the possible reasons for the contamination of shallow aquifer (Setu et al., 2014). In addition, thousands ha of land has been being irrigated based on groundwater for rice cultivation since last few decades.

### **Lack of appropriate aquifer**

Groundwater stores in impervious layers due to porous geological arrangements in the upper soil strata. For extraction of groundwater, medium sand is suitable. This sand has considerable porosity and can store a huge of water. Fine sand also can store a considerable amount of water. However, as the study area situated in the lower parts of the Ganges delta, the sediments of the region have very low permeability and don't seem to be able to store water (NWRPo, 1999). Moreover, Department of Public Health and Engineering (DPHE) officials of Dhaka said that the underground permeable layer of the coastal area isn't suitable for using as potable water due to having much fine sand. In some areas, tube-wells are not successful especially in the coastal belt because of saline water intrusion in the aquifer to a depth of 700-1000 feet (DPHE and UNICEF, 1989). Although, deep tube wells provide a relatively reduced level of saline water in the coastal areas but containing sand makes it undrinkable (Ahmed, 1996).

### **Identification of potable water scarce zone**

Accessibility to potable water within a suitable distance is a common problem in the coastal area of Bangladesh.

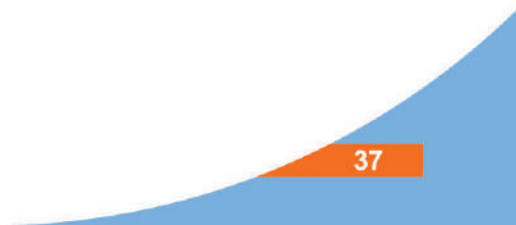





Another means of scarcity is inadequate supply of water. In the study area, there are total 28 community water sources for drinking purpose. Among them 15 were PSFs and 13 tube-wells. Though, there have a debate about the quality and uninterrupted supply over the year from those sources.

Distance from the sources is an important matter of water collection. Though, the criterion of Bangladesh government is having the safe drinking water source should be within 50 meters of household premise (GoB, 2005).

Distance of water source point from household

Collection of drinking water from a far distance is the main problem in the coastal area. Generally, the family members mainly housewives collect drinking water from another part of the village or from another village. The actual distance of the nearest water source from each household was determined in between the comparison of the user's reply and the author's observation.

Usually people are facing manifold problem in water collection where one of the major problem is distance. The suitable area of water supply is that, where the people can collect sufficient water without facing any trouble. Threshold area of water supply from existing sources is determined by the buffer of expected distance from the households. People are normally collect water minimum 50 m from their household premise.

Based on the observation, 200 m was determined as the suitable distance of water collection from the homestead. Based on this statement, adequate water accessible area was identified using 200 m radii from each water points. It is needed to mention that only homestead areas were considered during the demarcation.

## **6. Conclusions**

Potable water is basic for life. The people of this area are facing acute problem for safe drinking water. This study presents a detailed investigation of potable water scarcity and sources of water in a coastal community of Bangladesh. Many root causes, those create the difficulties for safe drinking water supply has been identified in this area. The constraints to potable water supply have been incorporated by reviewing relevant literatures.

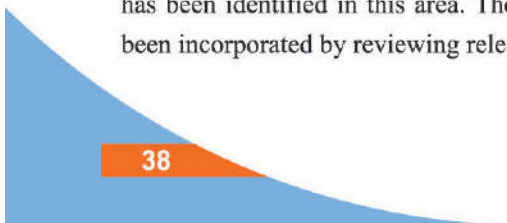



The water-scarce area has been calculated where the potable water supply is not suitable for collection. It was a two-dimensional study including the dwellers opinion of the suitable distance from their households and the spatial existence of the nearest water source from the homestead area.

The factors from reviewed literatures showed that those are highly persuasive for the limitation of potable water supply. The result also showed that a significant part (about two-thirds) of homestead area and a considerable number of households are beyond the suitable water zone, formulated by observation. The groundwater is not feet for consumption in most of the parts of this area. Moreover, the surface water especially large-pond water use is more suitable in considering environmental perspective.

Some suggestions have also been recommended to work out this drastic condition of suitable drinking water shortage like:

- \* Large pond should be considering as a dependent water-source;
- \* The existing PSF should be made proper functional by taken appropriate initiatives;
- \* The use of rainwater can be increased by the installation of more RWHS, and
- \* PSF can be installed on the reserve ponds, make assurance the quality of supplywater.

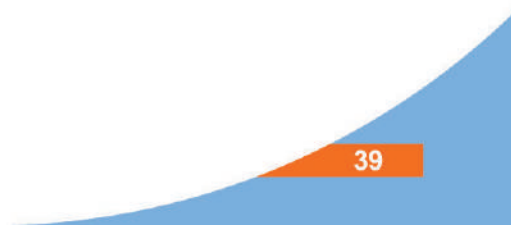



## References

---

Agrawala, S., Ota, T., Ahmed, A.U., Smith J., and Aalst, M. 2003. Development and climate change in Bangladesh: Focus on coastal flooding and the Sundarbans. Organization for Economic Co-operation and Development, Paris, France.

Ahmed, A.U. 2006. Bangladesh climate change impacts and vulnerability. Climate Change Cell, Department of Environment, Comprehensive Disaster Management Programme, Government of the People's Republic of Bangladesh, Dhaka, Bangladesh.

Ahmed, A.U. 2008. Desakota phenomenon observed in Satkhira-Khulna-Jessore-Dhaka corridor in the southwestern Bangladesh. Part II F1 of Desakota Study Team 2008, Centre for Global Change, Dhaka, Bangladesh.

Ali, A.M.S. 2006. Rice to shrimp: Land use/land cover changes and soil degradation in southwestern Bangladesh. *Land Use Policy*, 23: 421-435. DOI: <https://doi.org/10.1016/j.landusepol.2005.02.001>

Arsel, M., and Spoor, M. 2009. Political ecology of marshland restoration in Iraq. In: M. Arsel and M. Spoor (Eds.), *Water, environmental security and sustainable rural development: Conflict and cooperation in Central Eurasia*. Routledge, Abingdon.

Bangladesh Bureau of Statistics (BBS). 2014.

Bangladesh: Multi indicator cluster survey (MICS) 2012-2013. Bangladesh Bureau of Statistics, Statistics and Informatics Division, Ministry of Planning, Government of the People's Republic of Bangladesh.

BBS. 2015. Report on sample vital registration system (SVRS) 2013. Bangladesh Bureau of Statistics, Statistics and Informatics Division, Ministry of Planning, Government of the People's Republic of Bangladesh.

CEGIS. 2003. Analytical framework for the planning of 'Integrated water resources management'. Center for Environment and Geographic Information Services (CEGIS), Version 2.0., Dhaka, Bangladesh.

Chowhury, A.K.M.J.H., and Rasul, G. 2011. Equity and social justice in water resource governance: the case of Bangladesh. *South Asian Water Studies*, 2(2): 45-58.

Crow, B., and Sultana, F. 2002. Gender, class and access to water: three cases in a poor and crowded delta. *Society and Natural Resources*, 15(8): 709-724. DOI: [10.1080/08941920290069308](https://doi.org/10.1080/08941920290069308)

Cvjetanovic, B. 1986. Health effects and impact of water supply and sanitation. *World Health Statistics Quarterly*, 39(1): 105-117.

Datta, D.K., Roy K., and Hassan, N. 2010. Shrimp culture: trend, consequences and sustainability in the south-western coastal region of Bangladesh. In: A.L. Ramanathan, P. Bhattacharya, T. Dittmar, M.B.K. Prasad and B.R. Neupane (Eds.), *Management and sustainable development of coastal zone environments*, pp. 227-244. Springer, Dordrecht.





Deb, A.K. 1998. Fake blue revolution: environmental and socioeconomic impacts of shrimp culture in the coastal areas of Bangladesh. *Ocean Coast Management*, 41: 63-88. DOI:[https://doi.org/10.1016/S0964-5691\(98\)00074-](https://doi.org/10.1016/S0964-5691(98)00074-)

DMB. 2010. National plan for disaster management 2010-2015. Disaster Management Bureau, (DMB), Government of the People's Republic of Bangladesh.

DPHE and UNICEF. 1989. A report on the development of pond sand filtration. Department of Public Health Engineering, Dhaka, Bangladesh.

Halder, P.K. and Zaman, S. 2010. A term paper on impact of surge disaster on southwest coast of Bangladesh: A case study of cyclone 'AILA' on polder No-5. Institute of Water and Flood Management, Bangladesh University of Engineering and Technology, Dhaka, Bangladesh.

Haq, A.H.M. 2000. Integrated wetland system for mitigation of the salinization of southwest region of Bangladesh. Paper presented at the Eco Summit, 18-22 June, Nova Scotia, Canada.

Haque, M.A., Haque, A., and Ansari, M.S. 2010. Water, sanitation and health status of AILA affected coastal area of Bangladesh. *Bangladesh Journal of Environmental Science*, 19: 51-56.

Harun, M.A.Y.A., and Kabir, G.M.M. 2013. Evaluating pond sand filter as sustainable drinking water supplier in the southwest coastal region of Bangladesh. *Applied Water Science*, 3: 161-166. DOI: <https://link.springer.com/article/10.1007/s13201-012-0069-7>

Islam, S., and Kibria, Z. 2006. Unravelling KJDRP-ADB financed project of mass destruction in southwest coastal region of Bangladesh. Uttaran, Satkhira.

Jahin Shams Sakkhar, Zahid Amin Shashoto, Naveed Ferdous, Rafid Mahmud Khan - Finding Freshwater in a Changing Climate, Policy, Strategy and Technology in Southwest Coastal Region of Bangladesh. Uttaran, Satkhira

Islam, M. N. 2015. Community based adaptation to climate change in the exposed coastal areas of Bangladesh. Proceedings of the fifth International Conference on Water and Flood Management (ICWFM-2015), pp. 591-598. Institute of Water and Flood Management, Bangladesh University of Engineering and Technology, Dhaka, Bangladesh.

Islam, M.A., Karim, M.R., Higuchi, T., Sakakibara, H., and Sekine, M. 2014. Comparison of the trace metal concentration of drinking water supply options in southwest coastal areas of Bangladesh. *Applied Water Science*, 4(2): 183-191. DOI: <https://link.springer.com/article/10.1007/s13201-013-0140z>

Islam, M.R., Ahmad, M., Huq, H., and Osman, M.S. 2006. State of the coast 2006. Integrated Coastal Zone Management Project, Water Resource and Planning Organization, Dhaka.

Islam, R.M. and Ahmad, M. (2004). Living in the coast problems, opportunities and challenges. Integrated Coastal Zone Management Project, Water Resource and Planning Organization, Dhaka.



Kumar, U., Baten, M.A., Masud, A.A., Osman, K.S., and Rahman, M.M. 2010. Cyclone AILA: one year on natural disaster to human sufferings. Dhaka: UnnayanOnneshan - The Innovators.

M. Feroze Ahmed and Md. MujiburRahman; Water supply and Sanitation Rural and Low-income urban communitis, June 2000, ITN Bangladesh, Centre for Water Supply and Waste Management, BUET

Mehta, L. 2003. Contexts and constructions of water scarcity. *Economic and Political Weekly*, 38:5066-5072. DOI; <https://www.jstor.org/stable/4414344>

Moniruzzaman, M., and Rahman, M.A. 2011. Examine the water quality of pond sand filter (PSF): a study on Khontakata Union of Sarankhola Upazila, Bangladesh. *Journal of the Bangladesh National Geographical Association*, 39(1&2): 97-108.

Moniruzzaman, M., Rahman, M.A., and Hossain, M.S. 2012. Assessing the physical condition and management system of pond sand filter (PSF) of a coastal community of Bangladesh. *Journal of the Bangladesh National Geographical Association*, 40(1&2): 59-68.

NGO Forum for Public Health. 2012. Coping with coastal challenges. NGO Forum for Public Health, Dhaka, Bangladesh.

NWMP. 2001. National water management plan (NWMP), Volume 2, Main report. Ministry of Water Resources, Government of the People's Republic of Bangladesh.

NWRPo. 1999. National water resource policy (NWRPo). Ministry of Water Resources, Government of the People's Republic of Bangladesh.

Patil, P.G., and Krishnan, M. 1998. The social impacts of shrimp farming in Nellore District, India. *Aquac Asia*, 3: 3-5. PDO-ICZMP. 2004. Living in the coast: Problems, opportunities and challenges. Program Development Office for Integrated Coastal Zone Management Plan (PDO-ICZMP), Dhaka.

UNDP. 2006. Human development report 2006- beyond scarcity: power, poverty and the global water crisis. United Nations Development Programme (UNDP). Retrieved from:

<http://www.undp.org/content/dam/undp/library/corporate/HDR/2006%20Global%20HDR/HDR-2006-Beyond%20scarcity-Power-poverty-and-the-global-water-crisis.pdf>

Uttaran. 2003. Supaeopanirsandhane: quest for safe water, pp. 3. CARE and CIDA, Satkhira, Bangladesh.









## Uttaran

House # 32 (1st Floor), Road # 10/A  
Dhanmondi R/A, Dhaka -1209, Bangladesh.  
Tel: 88-02-91222, Cell: 88-01711828305  
e-mai: [uttaran.dhaka@gmail.com](mailto:uttaran.dhaka@gmail.com)  
web: [www.uttaran.net](http://www.uttaran.net)



## Uttaran

House # 32 (1st Floor), Road # 10/A  
Dhanmondi R/A, Dhaka -1209, Bangladesh.  
Tel: 88-02-91222, Cell: 88-01711828305  
e-mai: [uttaran.dhaka@gmail.com](mailto:uttaran.dhaka@gmail.com)  
web: [www.uttaran.net](http://www.uttaran.net)